

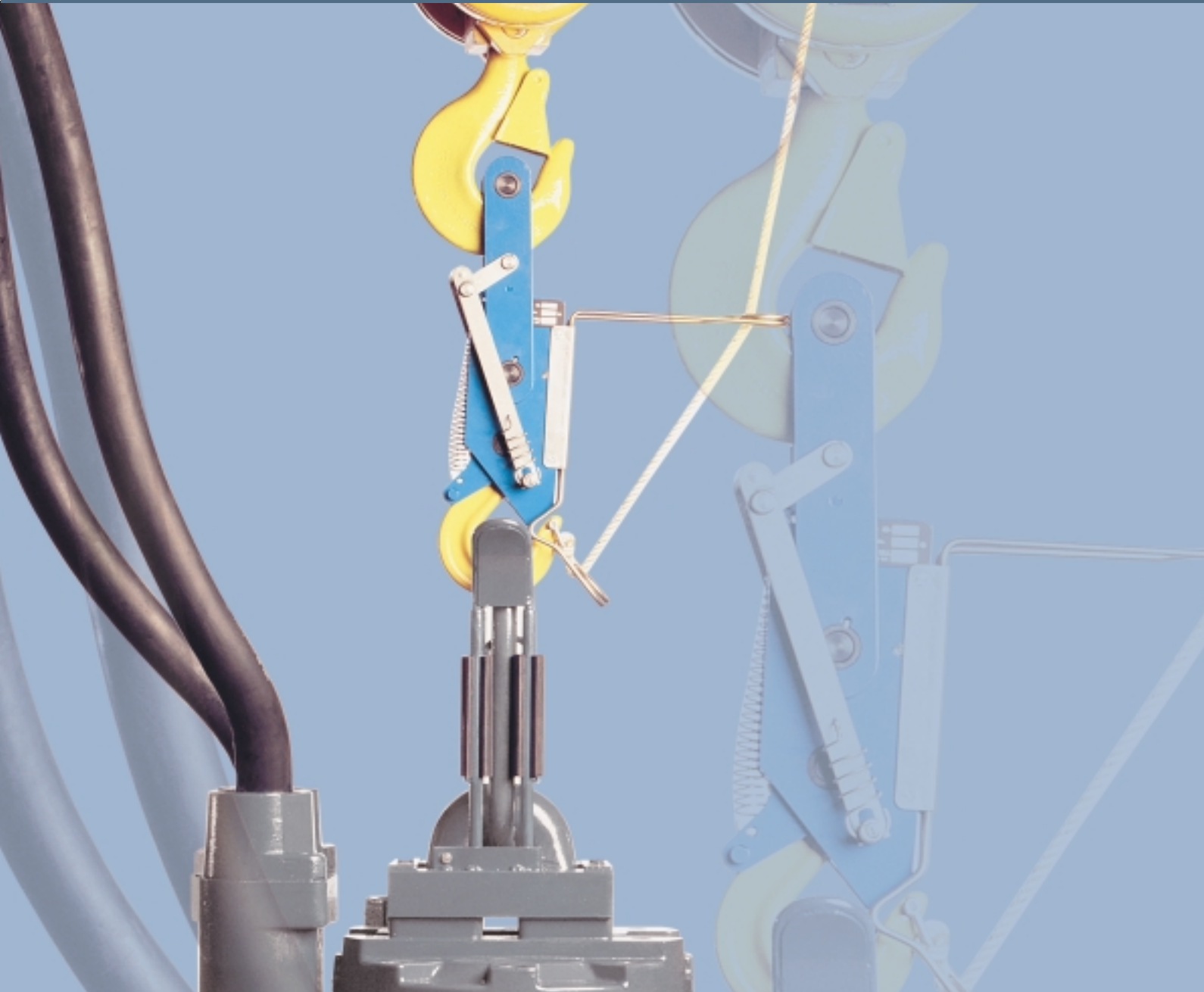

Dock-Lock™

A safer way to lift large submersible pumps



Flygt



ITT Industries
Engineered for life

From pumping systems to lifting systems

DockLock is a good example of the way we work: rather than just selling pumps, we aim to provide trouble-free pumping. So, whether it's a question of calculating hydraulic transients or simplifying your maintenance routines, ITT Flygt have the people and the products to make your workday that little bit easier.

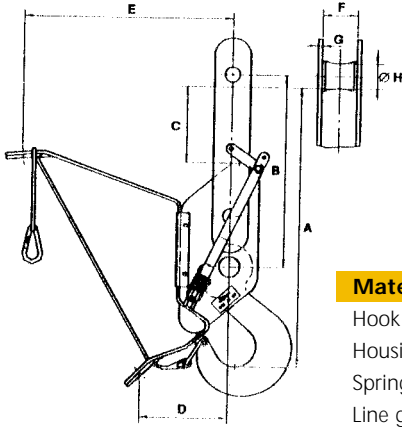
Dimensions	5 ton	10 ton	
	A	390 mm	550 mm
	B	280 mm	377 mm
	C	103 mm	149 mm
	D	104 mm	170 mm
	E	269 mm	402 mm
	F	67 mm	68 mm
	G	6 mm	8 mm
	H	36 mm	48 mm
	Weight	7 kg	15 kg
	Material		
Hook:	Steel, class 8		
Housing and link:	Heavy steel plate, HARDOX 400, (SSAB)		
Spring:	Sandvik 11R51 and 12R10		
Line guide:	Stainless steel DIN 17440, BS 970:1 304S15, AISI/ASTM:304		



www.flygt.com